

SPECIFICATION



DIESEL DUMPSTER | HTD-5

Maximum Carry Capacity 500kg Engine power: 4.4kW



A SMARTSTEP FORWARD IN SAFETY.

The new HTD5 is a compact, ride-on, high-tip, diesel-powered Dumpster designed to save you time, energy and money. Our new optional SmartStep feature maximises comfort and on-site safety.

IDEAL FOR ALL INDUSTRIES.

Our diesel Dumpster is ideal for the rental, housebuilding, landscaping, agricultural industries and many more.



OPTIMISED TRACK MOTORS.

New and improved track motors optimise the tracking performance allowing increased power on site, while two-speed tracking provides precision and accuracy.

INCREASED SECURITY.

We've introduced a removable JCB isolator to increase machine security by preventing unauthorised usage and theft.



EASY ACCESS.

A machine width of just 706mm allows you to fit through any standard doorway or gate.

EASY TIPPING.

A high-tip capability of 1.45m makes it easy to tip directly into a high sided vehicle or high side skip.

STATIC DIMENSIONS

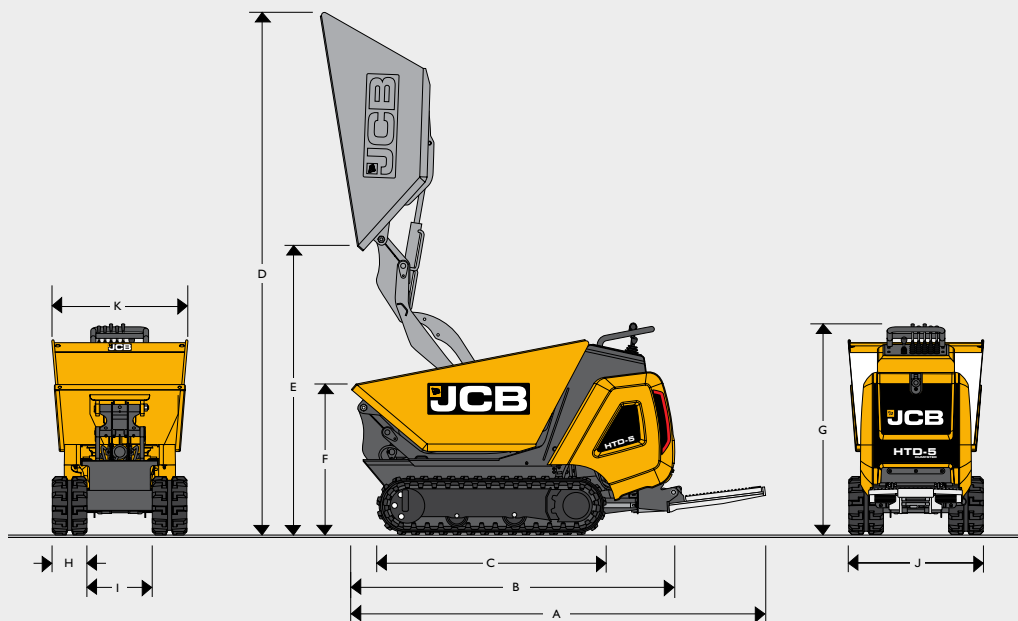

STATIC DIMENSIONS

A	Overall Length Step Down	mm	2152
B	Overall Length Step Up	mm	1770
C	Undercarriage overall Length - Rubber	mm	1166
D	Maximum height (tipping position)	mm	2720
E	Skip ground clearance (tipping position)	mm	1450
F	Minimum Skip height (transport position)	mm	780
G	Overall Height (transport position)	mm	1106
H	Single Track width	mm	180
I	Track spacing	mm	338
J	Maximum Track Width	mm	700
K	Maximum Machine Width	mm	706

ENGINE

Engine Model	kW (hp)	Kohler Engine with 4.4 (5.9) power
Fuel		Diesel
Cooling		Air Cooled
Gross power ISO 14396 (kW)	kW	4.4

UNDERCARRIAGE

No of bottom rollers		2
Track width rubber (STD)	mm	180
Track tensioning		Mechanical
Travel speed – high	kph	3

HYDRAULICS

Pump		Triple
Nominal output @ 3000rpm	lpm (gallons)	27 (6)
Main relief pressure	bar	150

WEIGHTS

Machine mass without step	kg	515
Machine mass with step	kg	590

SERVICE CAPACITIES

Fuel tank	ltr	4.3
Engine oil	ltr	1.2
Hydraulic system	ltr	13
Hydraulic tank	ltr	11.5

OPERATOR ENVIRONMENT

Two speed tracking provides precision and accuracy at low speeds
Higher speeds allow for quicker travel around site
Optimised track motors for enhanced tracking performance
Individual levers for ease of use and precise control
Compact turning circle for easy manoeuvring
Large carry capacity of 500kg.
Tip height of 1.45m allowing you to empty into a skip or high sided vehicle
Machine width of just 706mm allowing you to fit through any standard doorway or gate
Large opening panel for easy checks, servicing and maintenance
4.4kw (5.9 hp) Kohler diesel engine
1 year standard manufacturers warranty
New starter motor – better starts in cold environments
New enhanced track motors – improved track motors for optimised tracking performance
New machine isolator – a removable and securable isolator the same as all JCB standard machines
New horn system – Horn delivers an instant high pitch sound allowing workers to communicate in loud environments or in case of emergency

LIFT CAPACITIES

Maximum carry capacity	kg (lb)	500 (1,102)
Max machine load without step	kg (lb)	1,015 (2,238)
Max machine load with step	kg (lb)	1,090 (2,403)

OPTIONAL EQUIPMENT

SmartStep
Hour meter
Bullbar



ONE COMPANY, OVER 300 MACHINES.

Your nearest JCB dealer

Diesel Dumpster HTD-5

Maximum Carry Capacity 500kg Engine power: 4.4kW

JCB Sales Limited, Rokester, Staffordshire, United Kingdom ST14 5JP.

Tel: +44 (0)1889 590312 Email: salesinfo@jcb.com

Download the very latest information on this product range at: www.jcb.com

©2009 JCB Sales. All rights reserved. No part of this publication may be reproduced, stored in a retrieval system, or transmitted in any form or by any other means, electronic, mechanical, photocopying or otherwise, without prior permission from JCB Sales. All references in this publication to operating weights, sizes, capacities and other performance measurements are provided for guidance only and may vary dependant upon the exact specification of machine. They should not therefore be relied upon in relation to suitability for a particular application. Guidance and advice should always be sought from your JCB Dealer. JCB reserves the right to change specifications without notice. Illustrations and specifications shown may include optional equipment and accessories. All images are correct at time of print. The JCB logo is a registered trademark of J.C. Bamford Excavators Ltd.

29615 en-GB 10/21 Issue 1

